

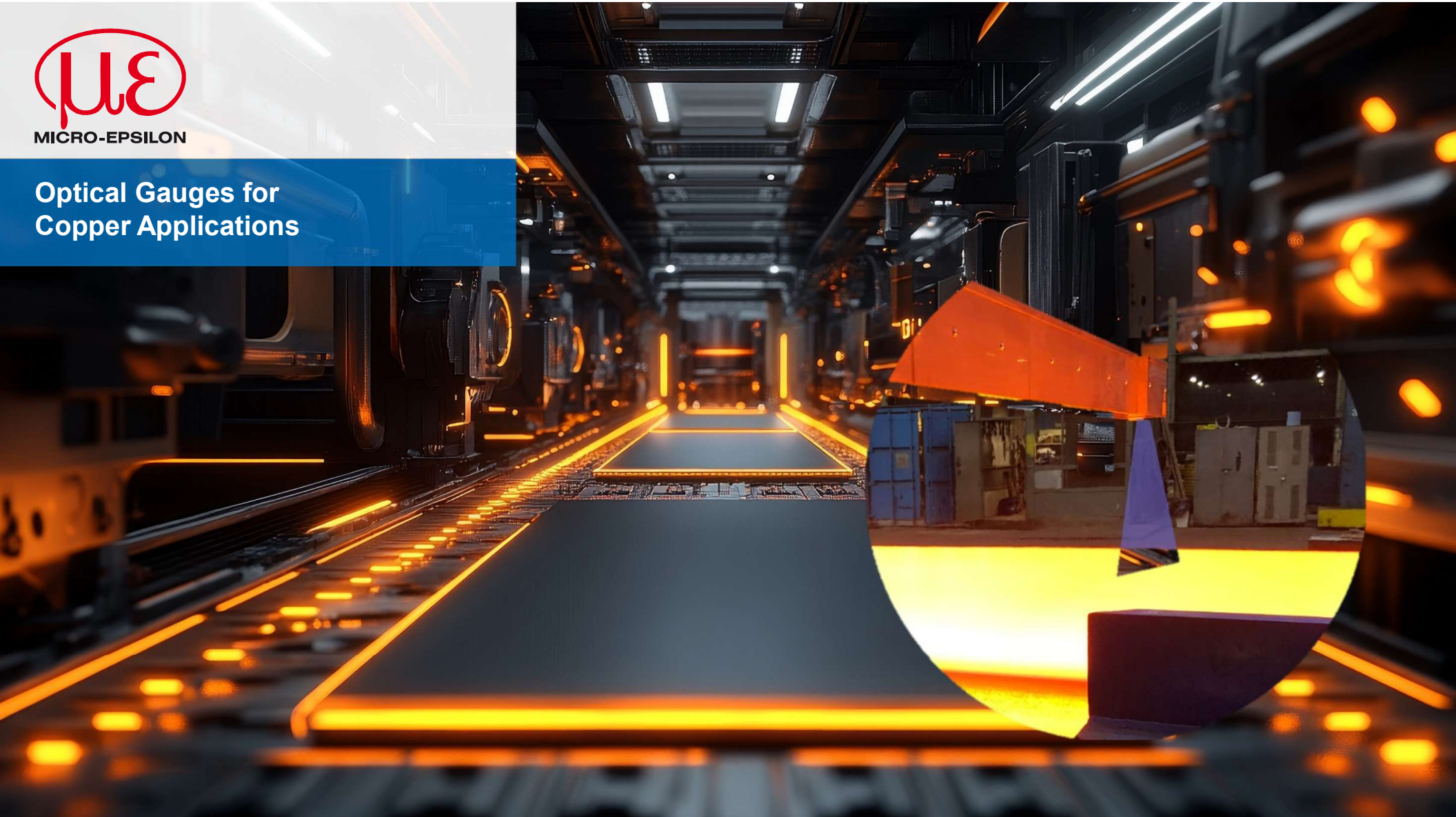

MICRO-EPSILON

## Optical Gauges for Copper Applications





## Optical Gauges for Copper Applications

### IWCC Legal Disclaimer

The purpose of this presentation is to guide programs benefiting the copper industry and to provide attendees with information to make independent business decisions.



## Micro-Epsilon Gauges stand for

- Innovative Technology
- Highest Precision
- Full Service Supplier
  - Sensors
  - Mechanics
  - Automation
  - Software

are covered entirely by the Micro - Epsilon company group

- Service and Support 24h/7d





## Applications

- Thickness
  - at a fixed track,
  - in the center
  - cross profile
- Edge drop (profile at the edge)
- Wedge, crown bow
- Width
- Camber

## Used for

- Gauge control
- Quality assurance
- Decision making





## Technologies & Applications



**Hot Rolling**



**Cold Rolling**



**Processing lines**



**Service Centers**



## Hot rolling

### Laser Line Triangulation

- Fully automated calibration based on certified gauge block
- 1280 points per profile, 100 profiles per second
- Best fit line as sensor value
- Patented laser color on red glowing metals

### Characteristics:

- Material width: 250 to 2500 mm
- Range: 400 (100/300) mm
- Accuracy:  $\pm 10, \pm 20 \mu\text{m}$

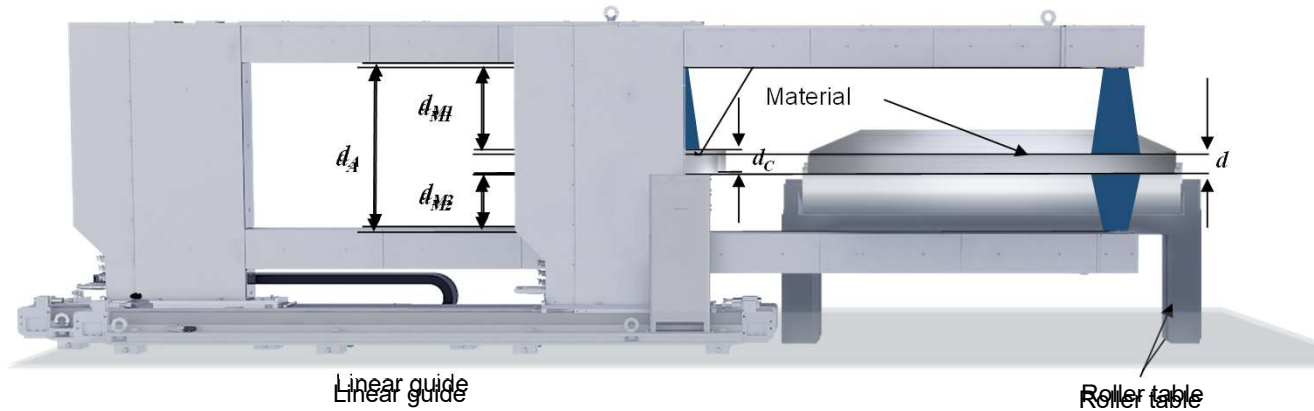

$$d_A = d_C + (d_{M1} + d_{M2})$$

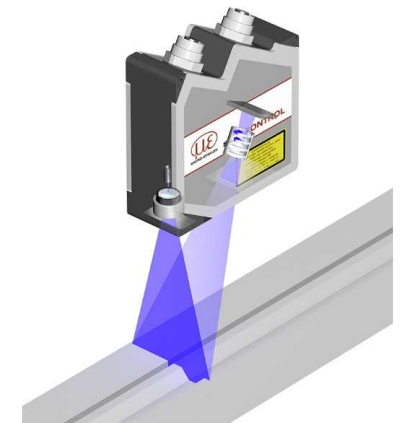
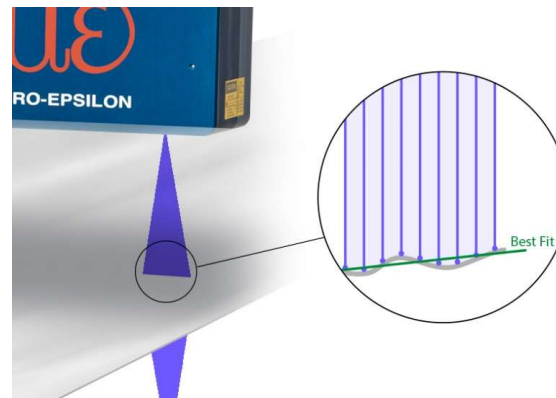



## Hot rolling

### Laser Line Triangulation

- Special sensors with double camera, 400 mm measuring range, accuracy  $\pm 10 \mu\text{m}$
- High-performance cooling system for material temperatures up to  $1200 \text{ }^\circ\text{C} / 2200 \text{ }^\circ\text{F}$
- Pneumatic mechanism protects optical systems
- Calibration and measurement independent of material and alloy

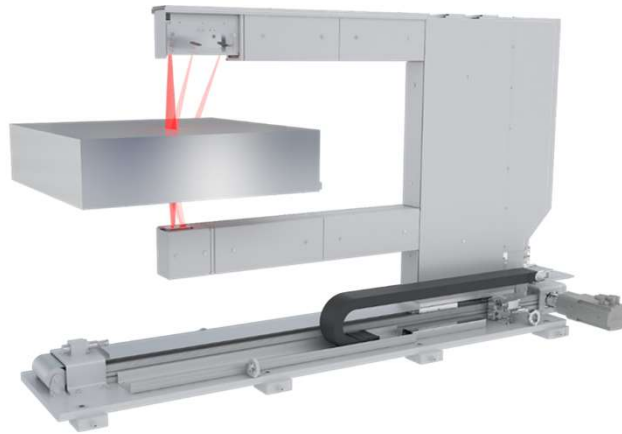

### thicknessCONTROL MTS 9202.LLT

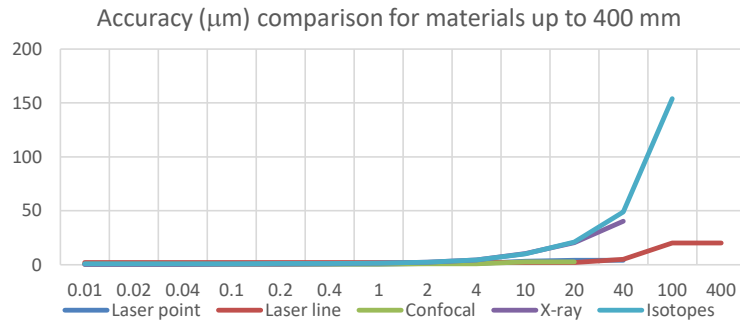
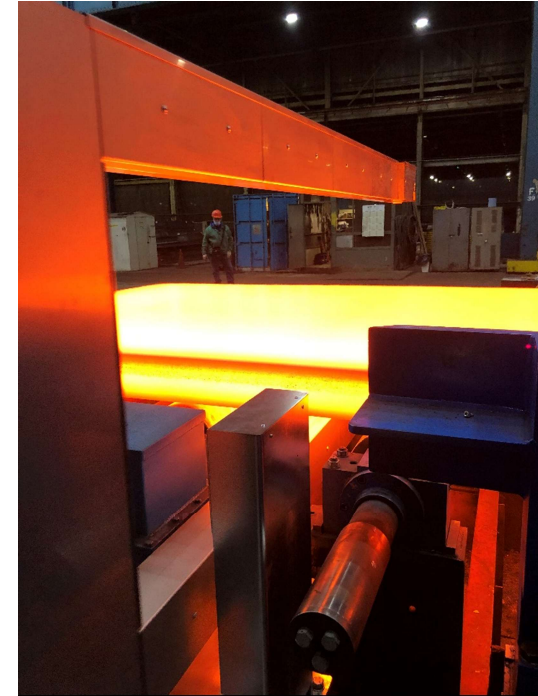

Typical accuracy ( $2\sigma$ ) for thick strips, plates and slabs.



## Hot rolling

### Laser Line Triangulation

- Special sensors with double camera, 400 mm measuring range, accuracy  $\pm 10 \mu\text{m}$
- High-performance cooling system for material temperatures up to  $1200 \text{ }^\circ\text{C}$  /  $2200 \text{ }^\circ\text{F}$
- Pneumatic mechanism protects optical systems
- Calibration and measurement independent of material and alloy

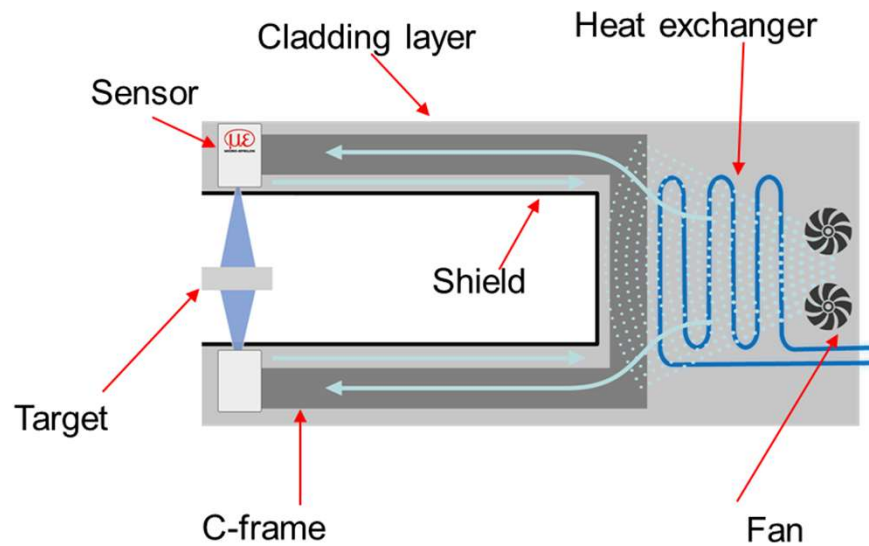
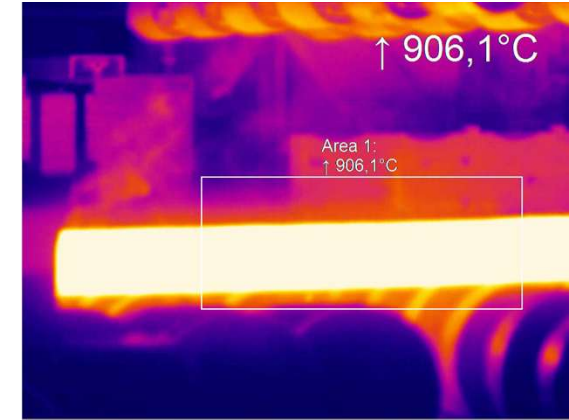
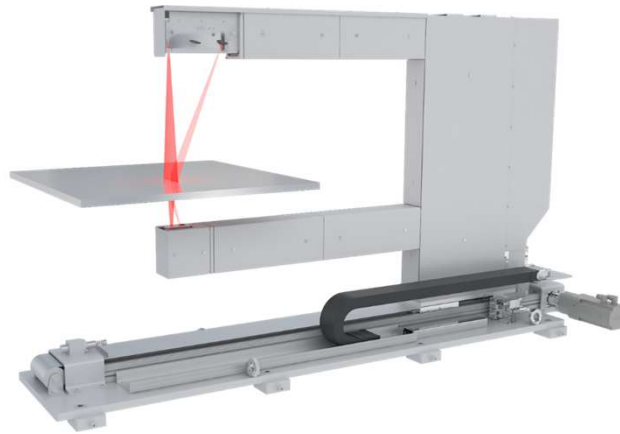



## Heavy Plates

### Edge measurement

- Covering big width dimensions with two frames
- Water cooling for hot rolling environment
- Integration of width & length measurement

### Characteristics:

- Material width: up to 6000 mm  
60/400
- Range: (100/300) mm
- Accuracy:  $\pm 10, \pm 40 \mu\text{m}$



thickness**CONTROL** MTS 9202.LLT

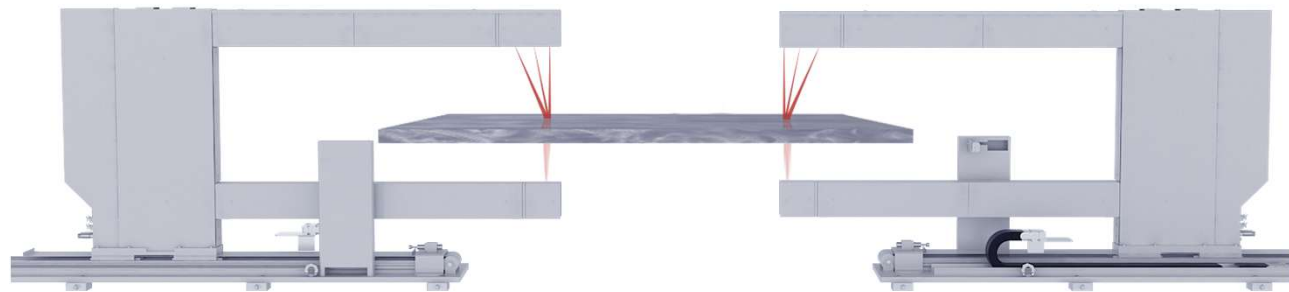



## Heavy Plates

### Edge measurement

- Covering big width dimensions with two frames
- Water cooling for hot rolling environment
- Integration of width & length measurement

### Characteristics:

- Material width: up to 6000 mm  
60/400
- Range: (100/300) mm
- Accuracy:  $\pm 10, \pm 40 \mu\text{m}$

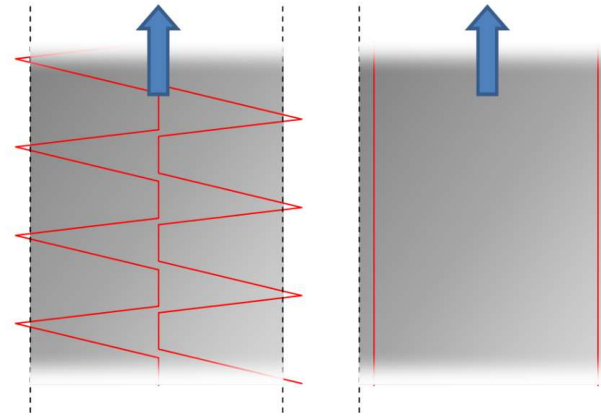

Measurement modes with two frames





## Cold rolling

### Confocal technology

- Nano resolution
- Extremely small spot size
- Big standoff relativ to the accuracy
- Surface-independent, also suitable for mirror-like surfaces
- Can measure multiple reflections

### Characteristics:

- Material width: 250 to 1000 mm
- Range: 3, 10, 20 mm
- Accuracy:  $\pm 0.4$ ,  $\pm 0.7$ ,  $\pm 2.5$   $\mu\text{m}$

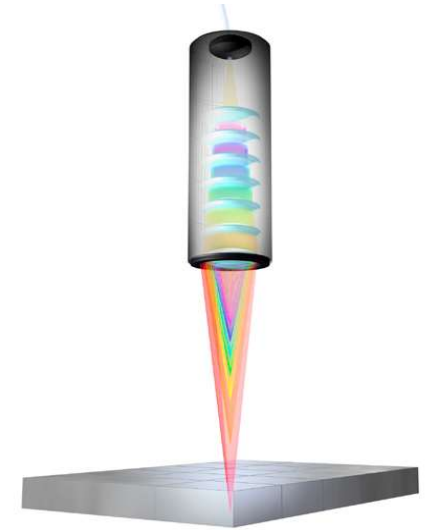

thickness**CONTROL** MTS 8202.K

Accuracy ( $\mu\text{m}$ ) comparison for materials up to 10 mm thick

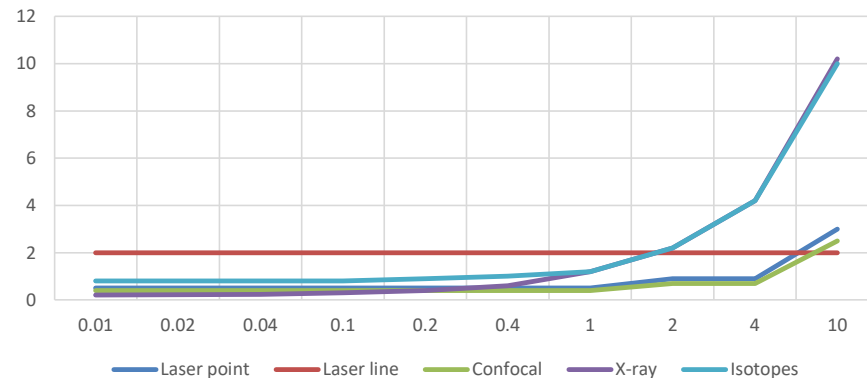

Typical accuracy ( $2\sigma$ ) for thin strips and sheets.



Processing lines/Service centers

Laser line technology  
Detection and compensation of

- Tilt: slitting lines/coiler
- Oil film
- Emulsion, scale

Measurement of profiled surfaces

- Checker plate/ tread plate

Characteristics:

- Material width: max 4000 mm
- Range: 60 mm
- Accuracy:  $\pm 2.0 \mu\text{m}$



thicknesCONTROL MTS 8202.LLT

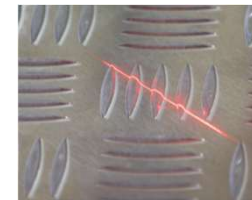
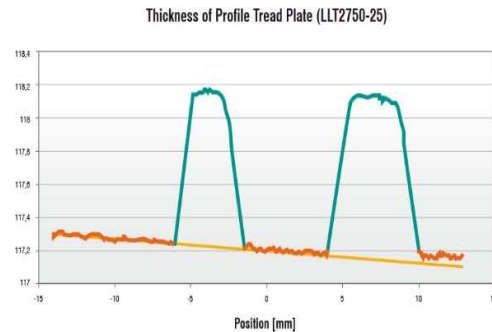



## Processing lines/Service centers

### Laser line technology

- Highly precise
- Patented compensation of thermal influence
- High traversing speed up to 64m/min
- Up to 3 tracks

### Characteristics:

- Material width: max. 4000 mm
- Range: 60 mm
- Accuracy:  $\pm 2.0 \mu\text{m}$



thicknesCONTROL MTS 8201.LLT

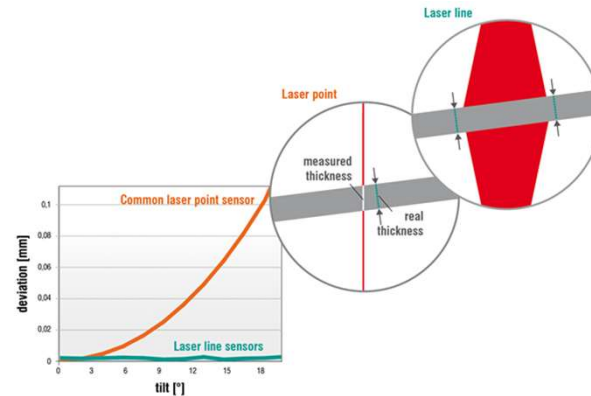



## Patented compensation of thermal impact

- Multiple sources of temperature changings have influence on the mechanical structure

$$d = d_A - (d_{M1} + d_{M2})$$

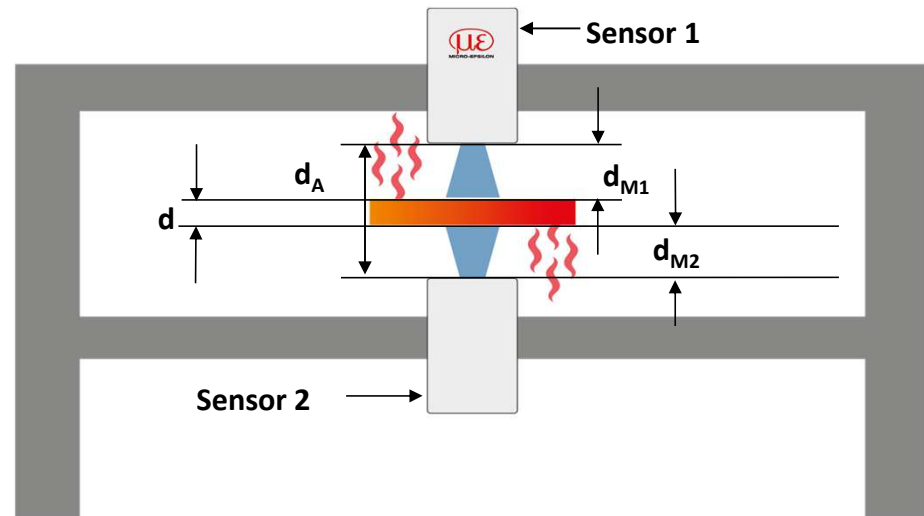
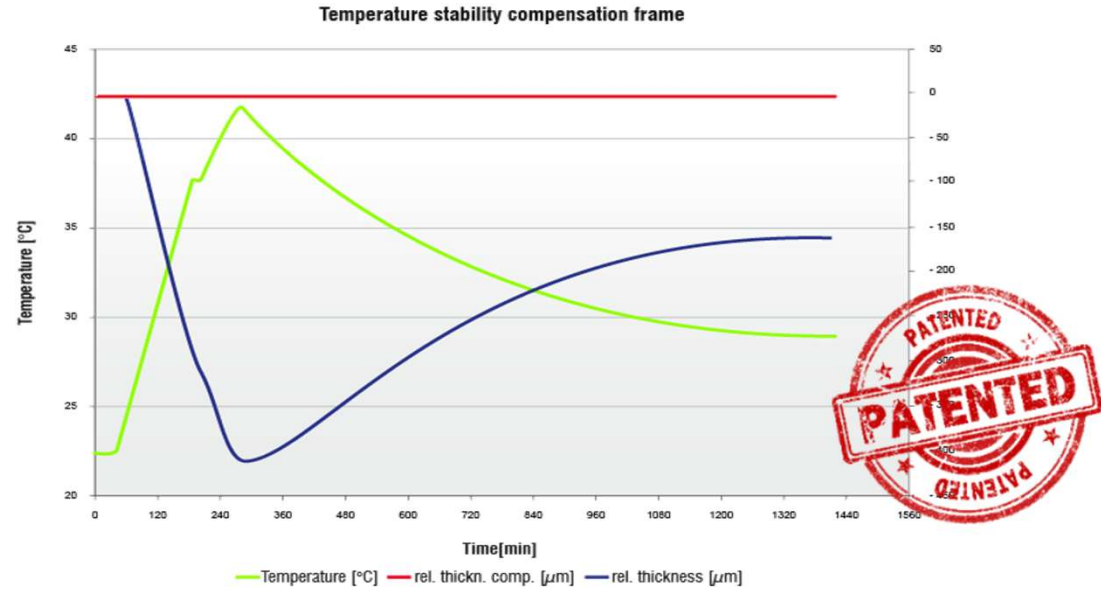
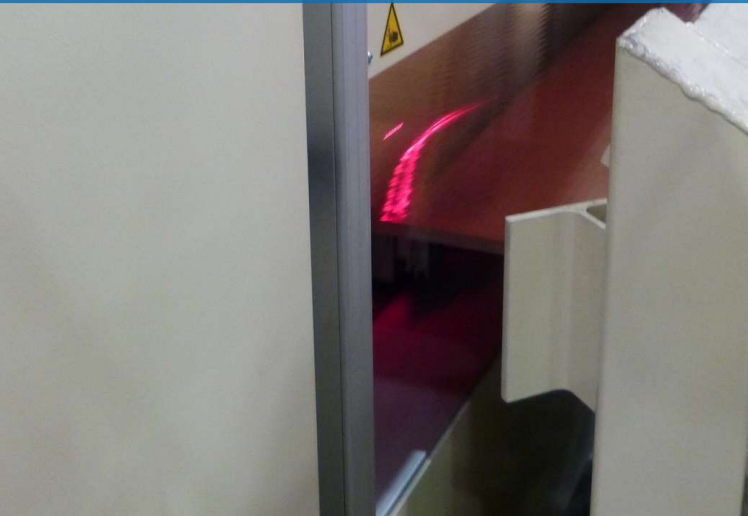



## Patented compensation of thermal impact

- Vertical deviation of the mechanical structure is reflected in the result

$$\Delta d = \Delta d_A$$

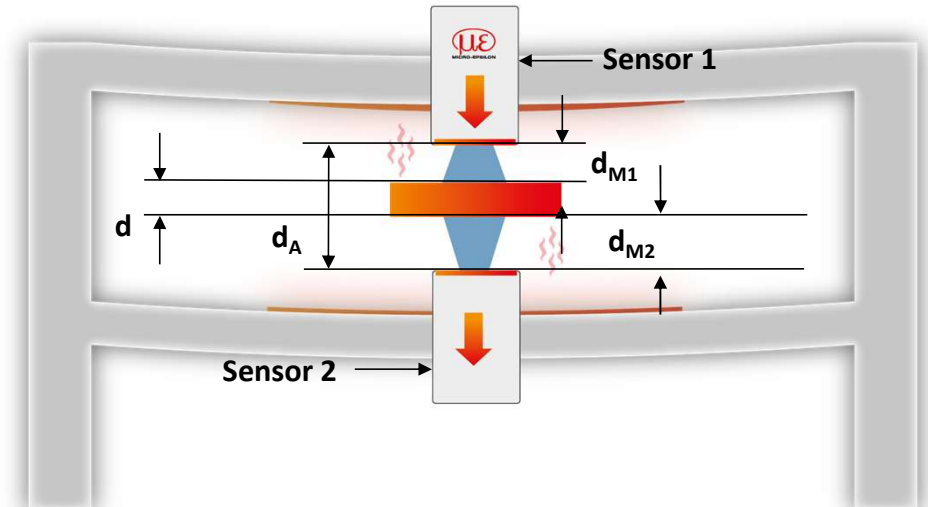
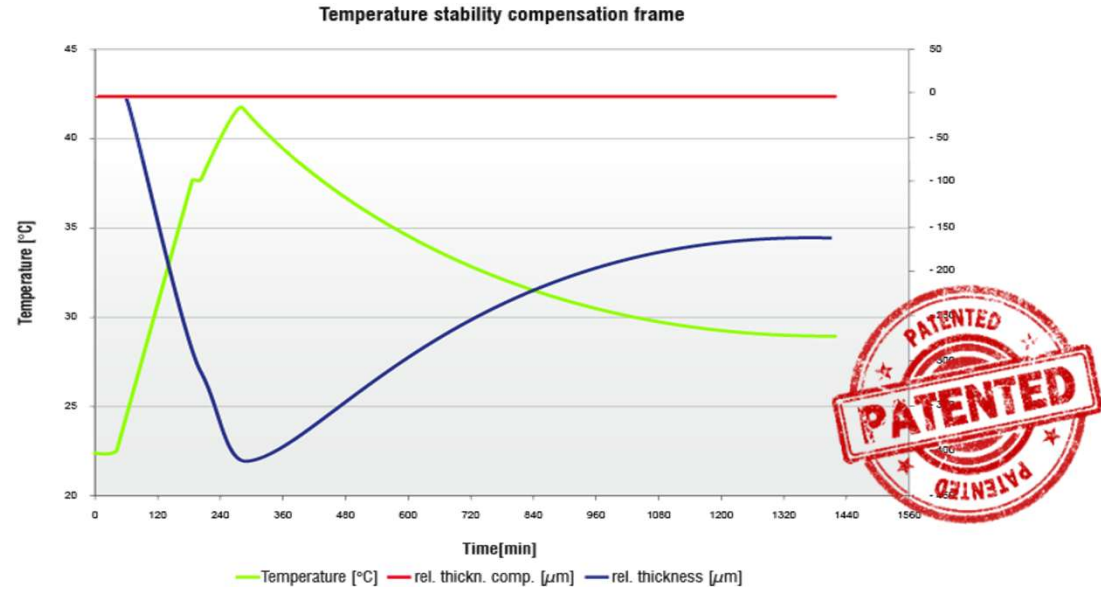
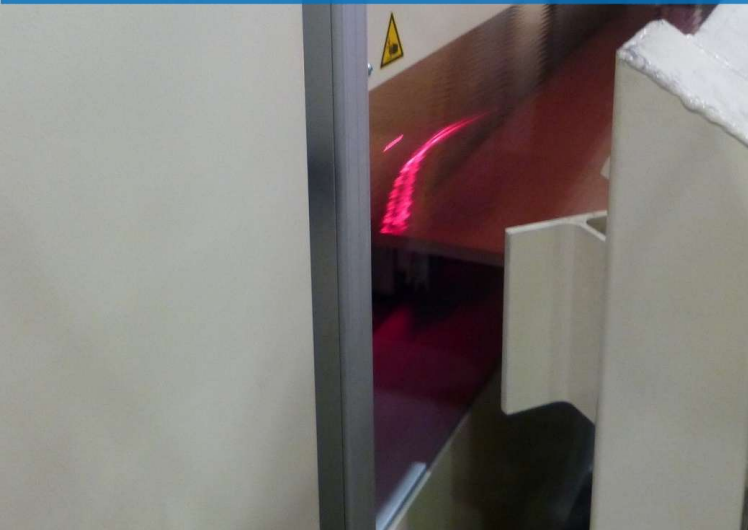



## Patented compensation of thermal impact

- Integration of a temperature stable compensation frame
- Integration of additional compensation sensors

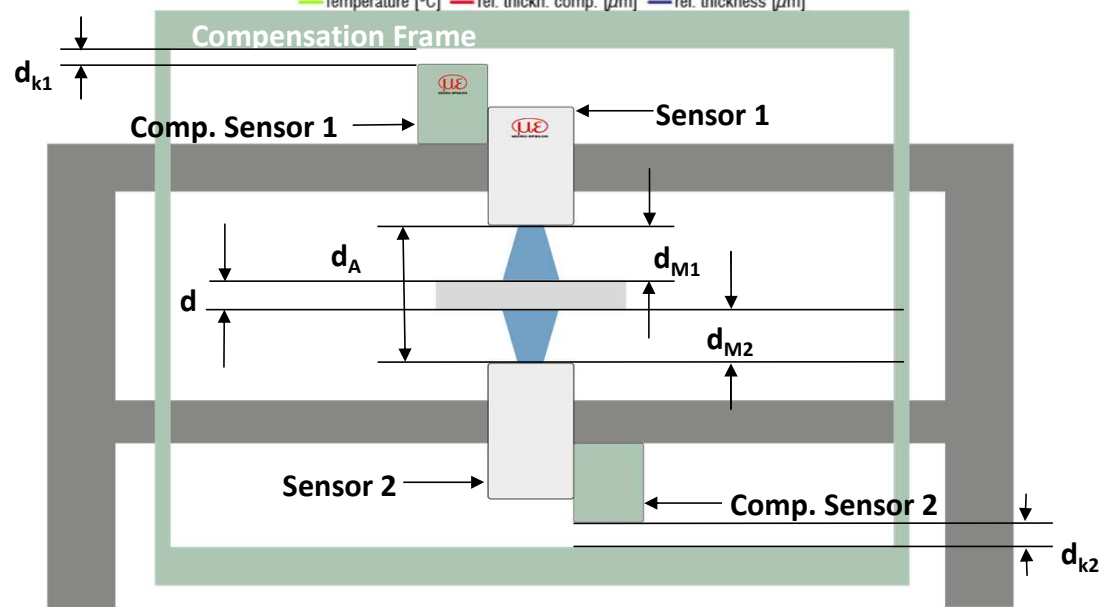
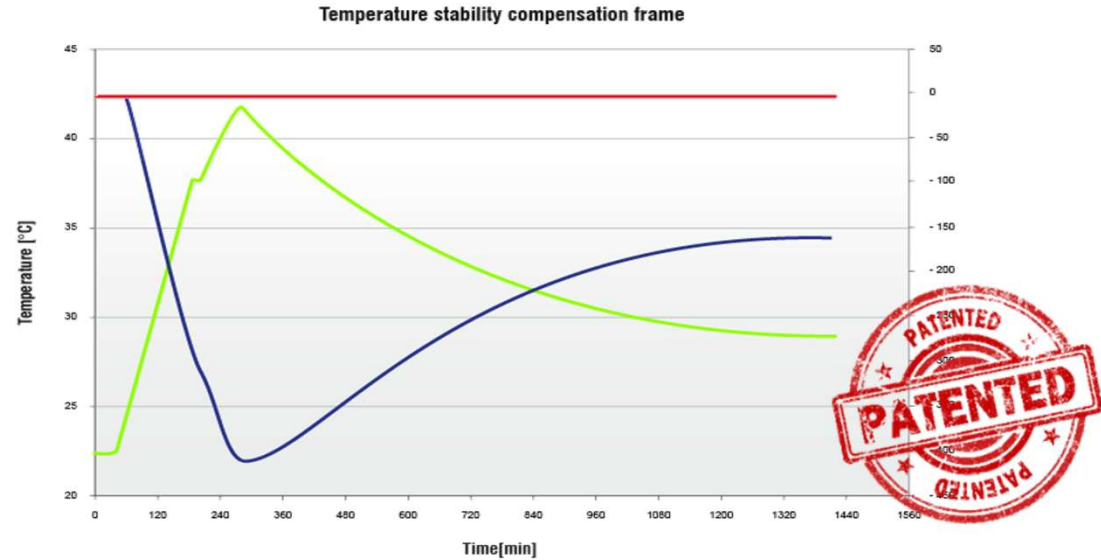
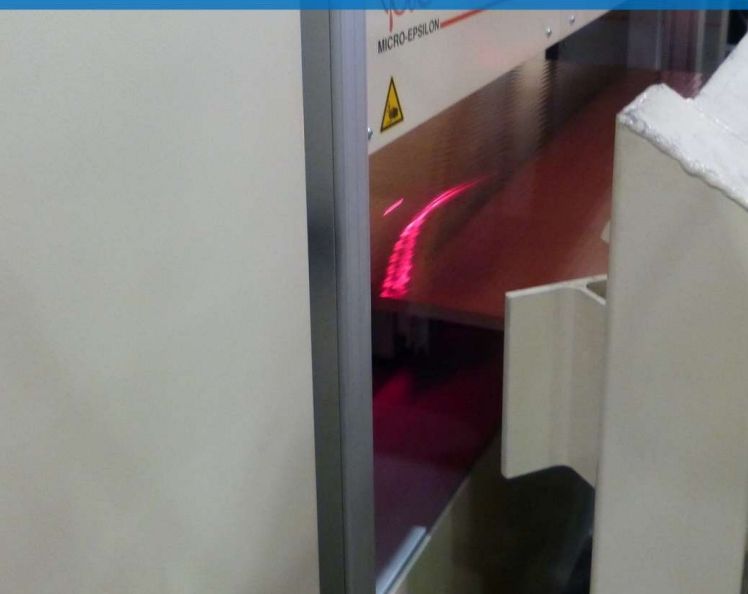



## Patented compensation of thermal impact

- Compensation of vertical deviation
- Gap is virtual constant

$$\Delta d_{k1+k2} = -\Delta d_A$$

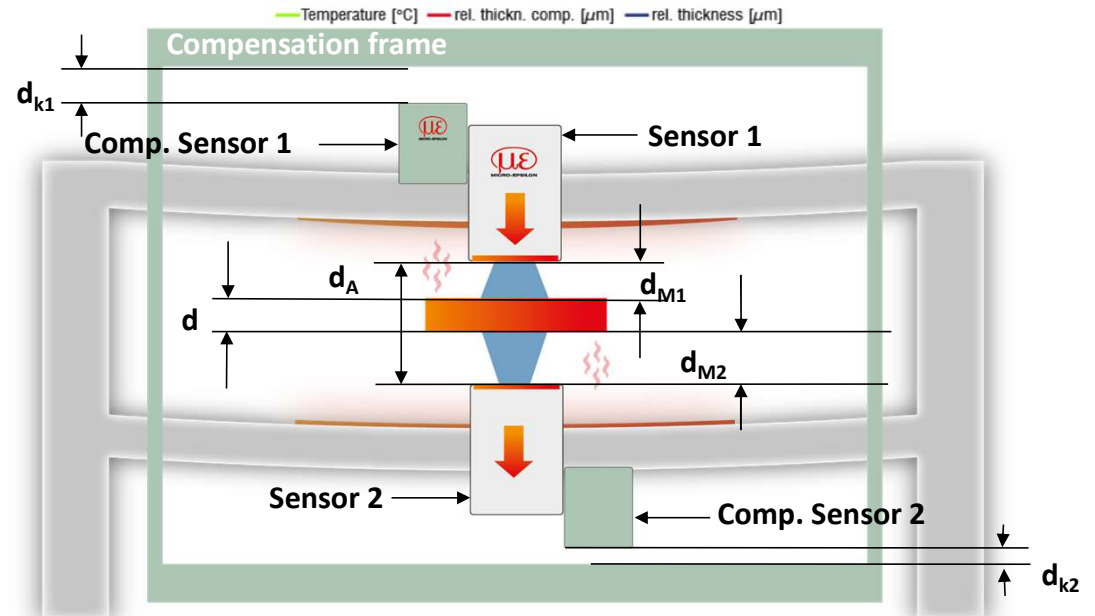
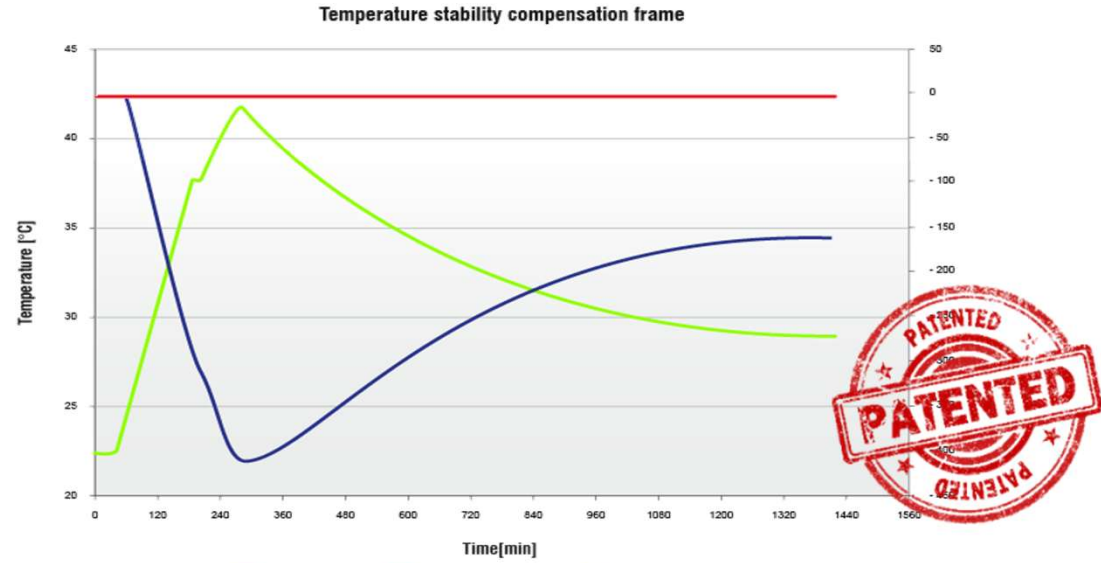
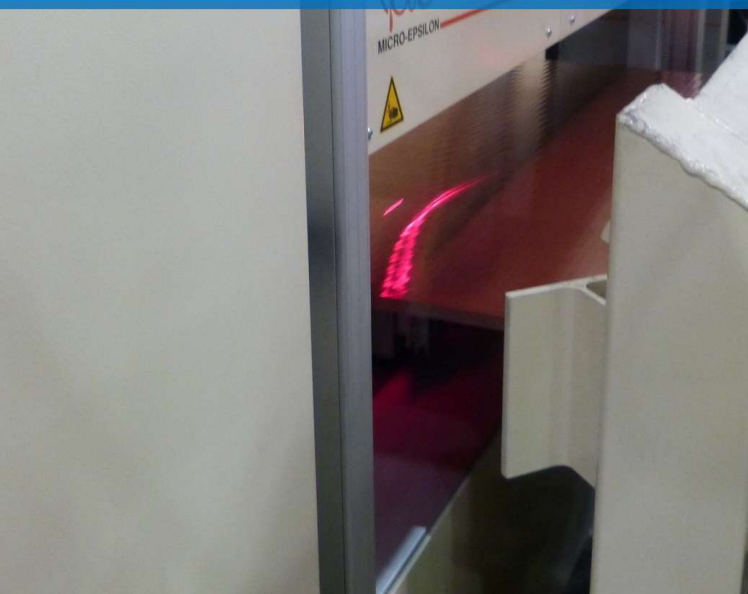



## Processing lines/Service centers

### Laser line technology

- Highly precise
- Patented compensation of thermal influence
- High traversing speed up to 64m/min
- Up to 3 tracks

### Characteristics:

- Material width: max. 4000 mm
- Range: 60 mm
- Accuracy:  $\pm 2.0 \mu\text{m}$



thicknessCONTROL MTS 8201.LLT

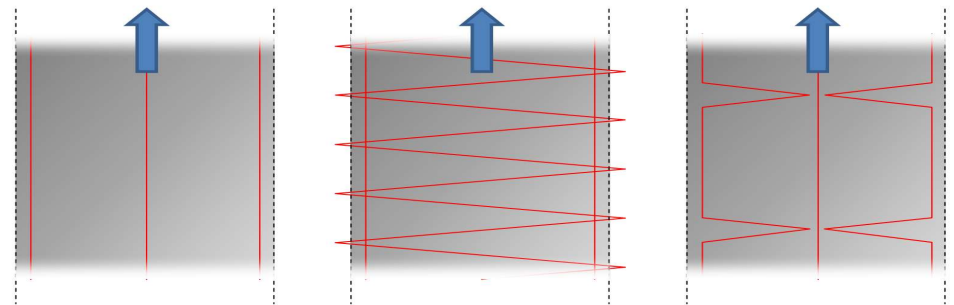

Measuring modes with 3 tracks



## Comprehensive Software Package

- Multi-touch architecture
- Controllable by touch gestures
- Recipe database
- Easy modification of settings
- Alternatively controllable over fieldbus or network interface
- Multiple views and evaluations

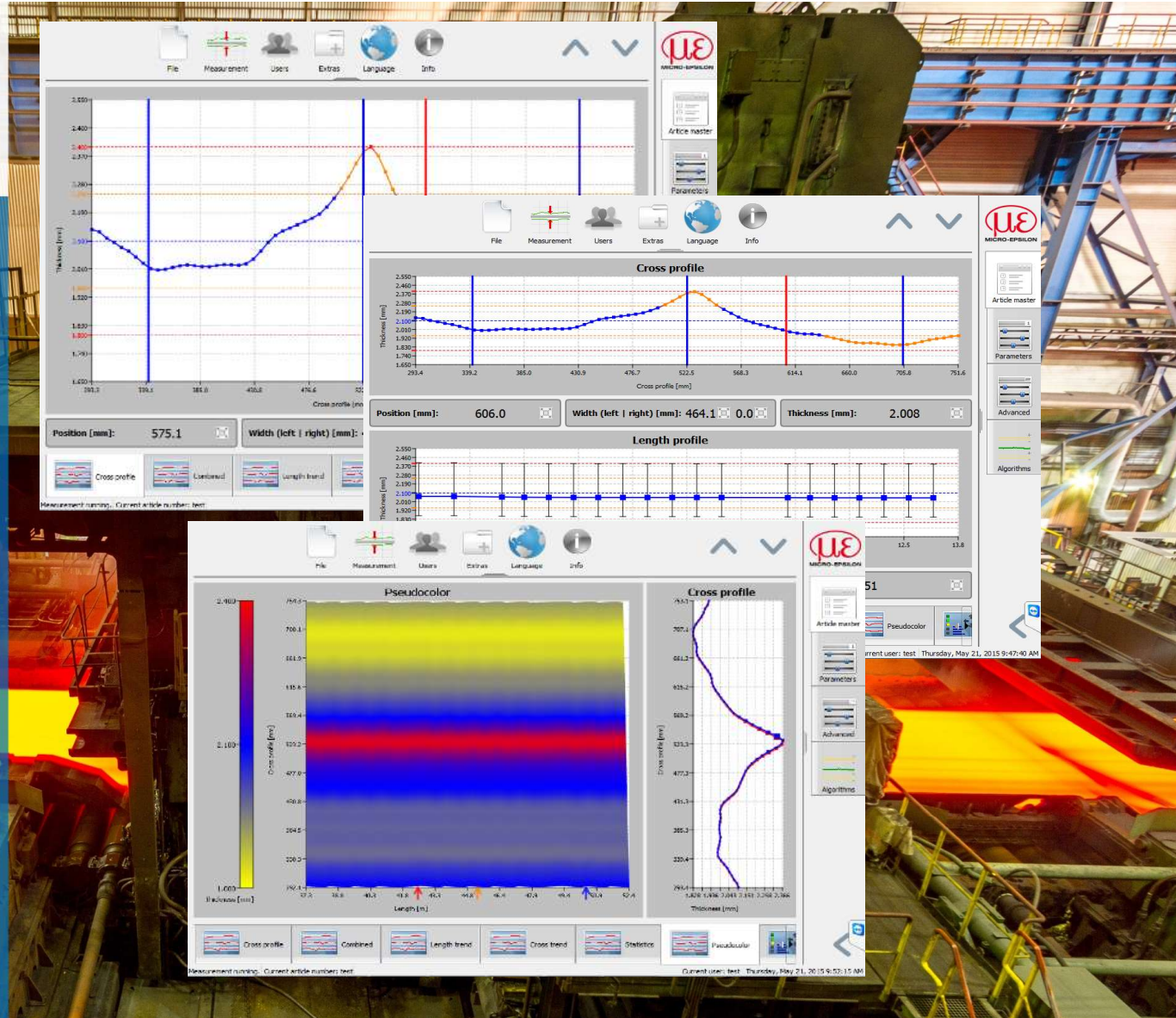



## Non-contact thickness measurement in battery cell production

- Reliable and precise measurement of film thickness and coating application
- High performance product range

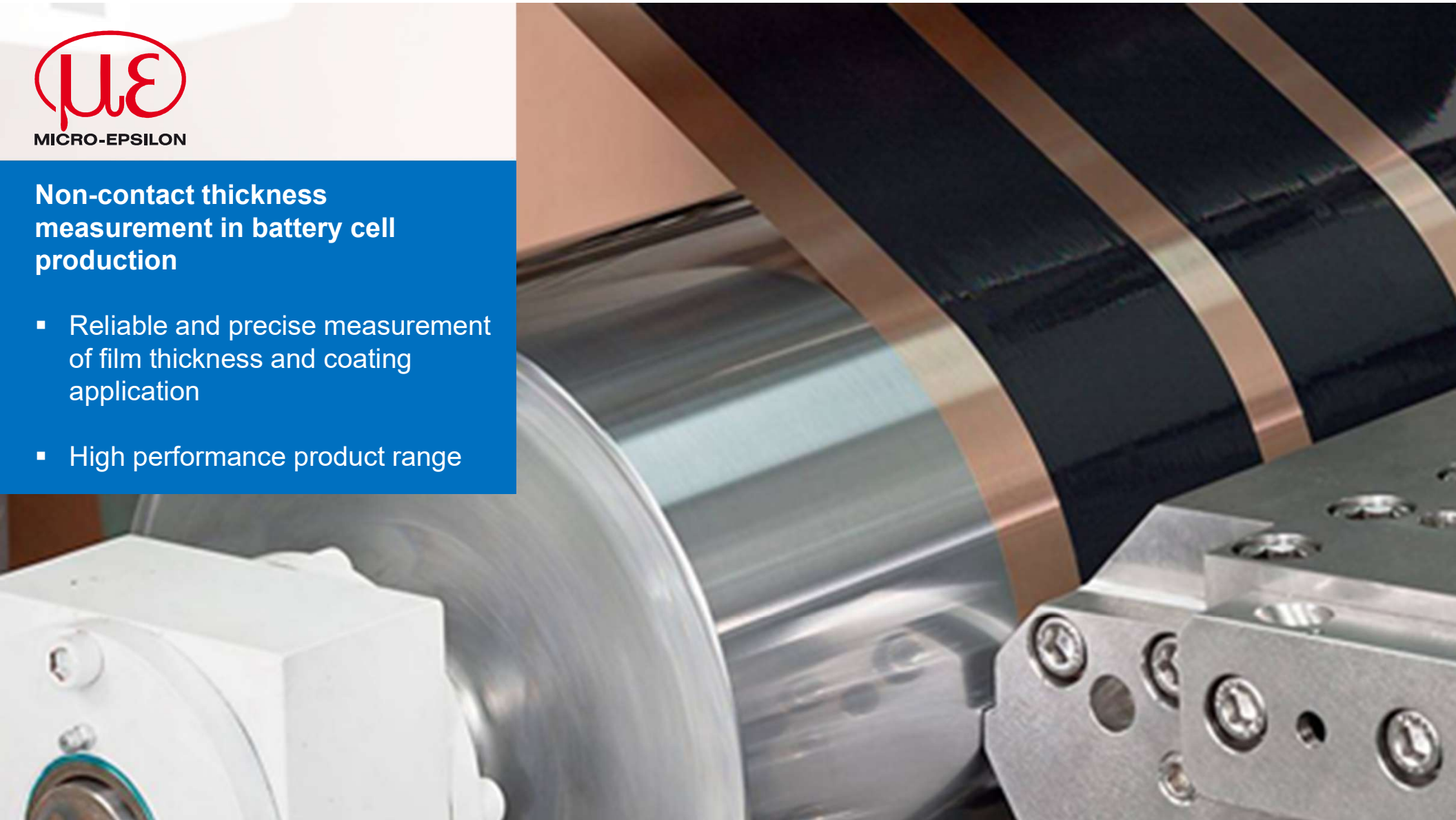



## Coating lines for Battery Production

### Confocal technology

- Entry level & scaled production
- Highly precise
- Up to 8 tracks

### Characteristics:

- Material width: max. 1600 mm
- Range: 6 mm
- Accuracy:  $\pm 0.5 \mu\text{m}$

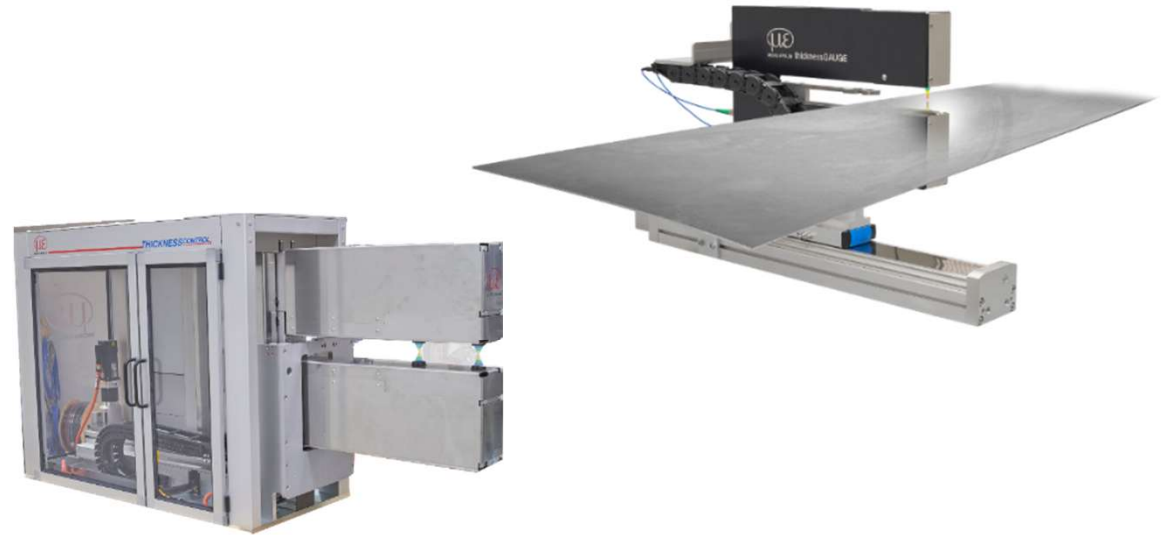

thicknessCONTROL BTG 8702.C

## OEM ready 2D evaluation of 3D Application thicknessGAUGE 3D

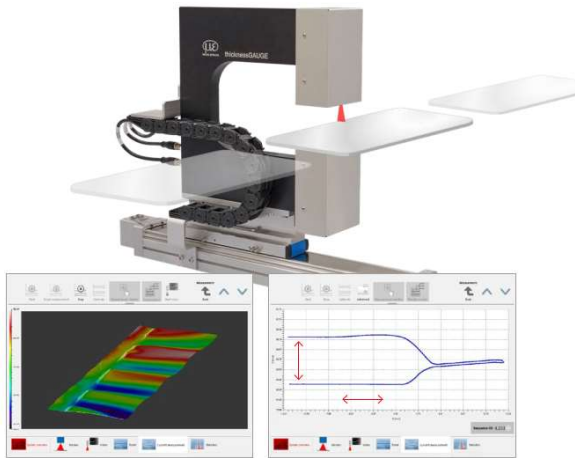

### Sensor systems for precise thickness gauging

thicknessGAUGE C.LP – 3D -15 / 200/400/600

- Hardware identical with thicknessGAUGE C.LP
- Automatic calibration
- Measuring range:

Z-Axis:	15 mm
X-Axis:	26,8 mm (max.)

- System accuracy:  $\pm 1,2 \mu\text{m}$
- Measuring speed: 500 Hz (opt. 2 kHz)
- Resolution:

Z-Axis:	0,2 $\mu\text{m}$
X-Axis:	1.024 points (opt. 2.048)

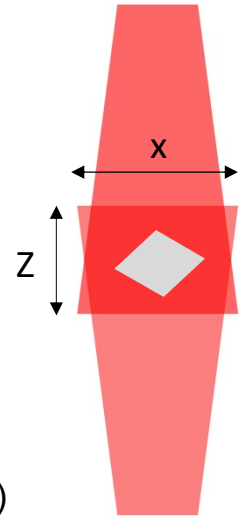

## OEM ready 2D evaluation of 3D Application thicknessGAUGE 3D

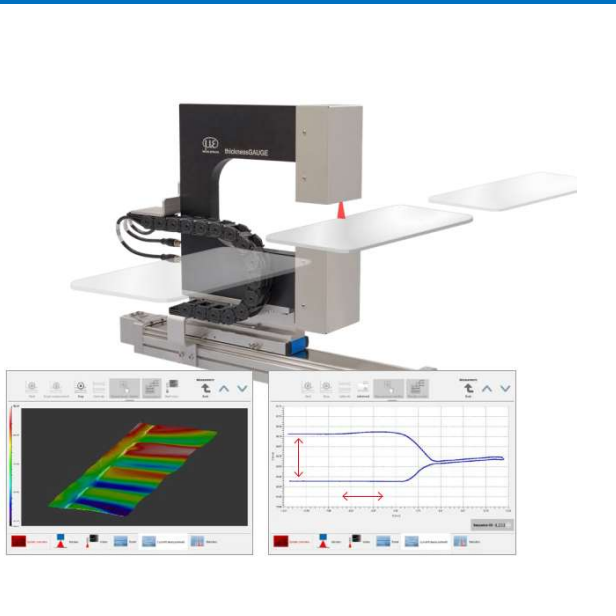

### Sensorsystems for precise thickness gauging

thicknessGAUGE C.LP – 3D -15/200/400/600

Additionally software package profileGAUGE

- profileGAUGE is based on the profileUNIT-Software:
- Functionality:
  1. Profile Acquisition
  2. Generation of 3D-Inspection recipe
  3. Transfer of recipe to profileGAUGE software
  4. 2D Evaluation of target feature, e.g. webs, grooves, chamfers, drill holes, etc

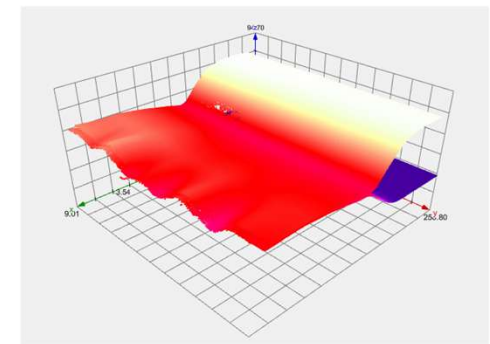
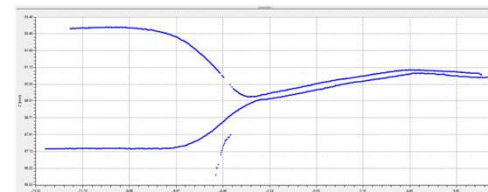
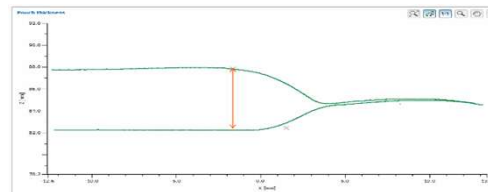



**THANK YOU FOR YOUR ATTENTION**

Follow us on

